

	CUSTOMER	CUSTOMER CODE	PART DESCRIPTION HALL EFFECT CURRENT SENSOR CLOSED LOOP 6A		
	INTERNAL CODE HCT-06DSR5	DATE 02/11/10	EDITION 2	DOCUMENT NAME HCT-06DSR5_2.doc	PAGE 1/16

HCT-06DSR5 SERIES HALL EFFECT CURRENT SENSOR CLOSED LOOP

NOTES



All rights reserved. Passing on of this document, use and communication of contents not permitted without written authorisation.

	CUSTOMER	CUSTOMER CODE	PART DESCRIPTION HALL EFFECT CURRENT SENSOR CLOSED LOOP 6A		
	INTERNAL CODE HCT-06DSR5	DATE 02/11/10	EDITION 2	DOCUMENT NAME HCT-06DSR5_2.doc	PAGE 2/16

1.- DIMENSIONS AND PINS CONFIGURATION

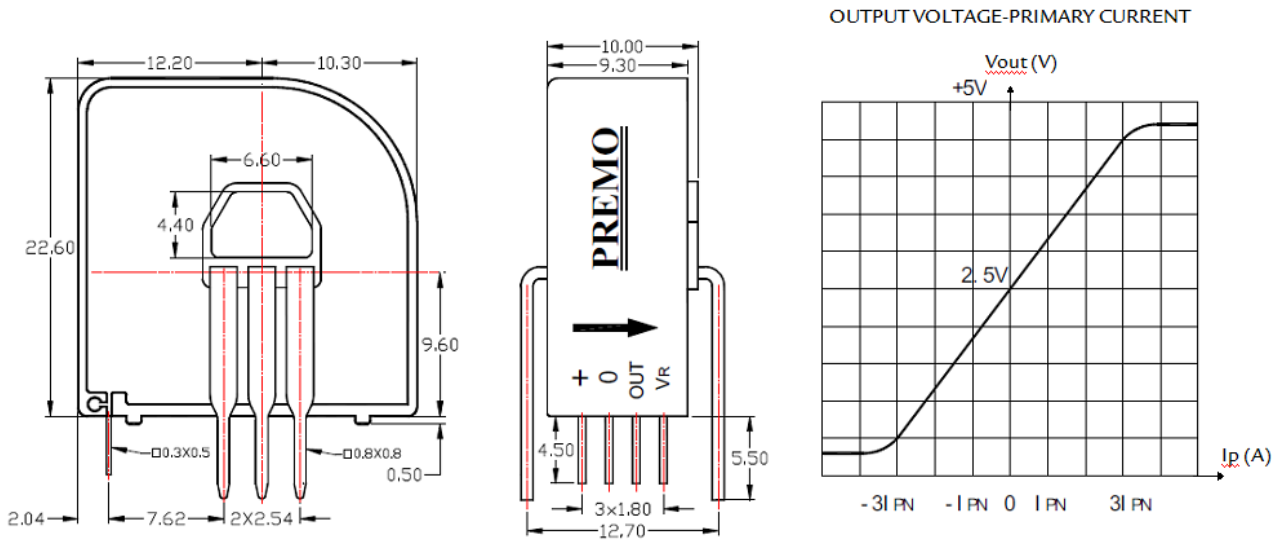

All dimensions are in mm.

General Tolerance ± 0.5 mm.

All dimensions and mechanical fixations are subjected to change depending on the customer necessities and PREMO Transducer Development.

The reference pin is only Output.

Marking

Component is marked as follows:

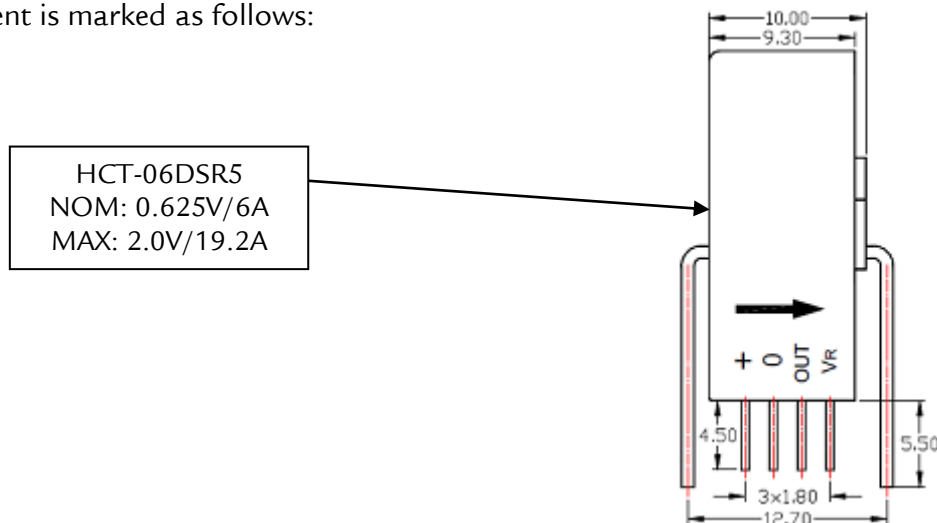

NOTES

All rights reserved. Passing on of this document, use and communication of contents not permitted without written authorisation.

	CUSTOMER	CUSTOMER CODE	PART DESCRIPTION HALL EFFECT CURRENT SENSOR CLOSED LOOP 6A		
	INTERNAL CODE HCT-06DSR5	DATE 02/11/10	EDITION 2	DOCUMENT NAME HCT-06DSR5_2.doc	PAGE 3/16

2.- ELECTRICAL PARAMETERS

Primary Nominal Current	6 A RMS	I_{PN}
Measuring Range	19.2 A	I_P
Reference voltage	$2.5 \pm 0.5\%$ V	V_{REF}
Turns	960 ± 1	N
Supply Voltage	$+5 \pm 5\%$ V	V_{CC}
Rated output (V)	$0.625 \pm 0.5\%$	V_O
Sample resistance inside	$100 \pm 0.1\%$ Ω	R_{IN}

3.- ACCURACY

Linear Error	< 0.1 % Full Scale	e_{LLR}
Total precision	± 0.7	
Offset Current Drift	$\pm 0.5\%$ mV/°C	K_{Ios}
Time Response ($di/dt > 50$ A/ μ S)	< 500ns	T_R
Frequency Bandwidth	DC to 200kHz (-1dB)	F_c

4.- GENERAL DATA

Operating Temperature	-40 to +85 °C	T_A
Storage Temperature	-40 to +125 °C	T_s

5.- ISOLATION CHARACTERISTICS

Galvanic isolation (50 Hz, 1min)	2.5 KV	V_i
Impulse withstand voltage 1.2/50 μ s	>8 KV MIN	V_w
Creepage distance	15.35 mm	d_{Cp}
Clearance distance	6.2 mm	d_{Cl}

STANDARDS

	EN 50178	UL 508C
Rating isolation voltage	600V	600V
Pollution degree	2	2
CTI	III	III

Notes:

-To be certificated

NOTES

All rights reserved. Passing on of this document, use and communication of contents not permitted without written authorisation.



	CUSTOMER	CUSTOMER CODE	PART DESCRIPTION HALL EFFECT CURRENT SENSOR CLOSED LOOP 6A		
	INTERNAL CODE HCT-06DSR5	DATE 02/11/10	EDITION 2	DOCUMENT NAME HCT-06DSR5_2.doc	PAGE 4/16

6.- MOUNTING DIMENSIONS (FOR REFERENCE ONLY)

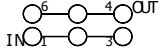
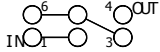
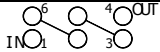
Turns	Primary rated current IPN[A]	Rated putout voltage VOUT[V]	Primary resistance [mΩ]	Primary Inductance [uH]	Connect point
1	±6	2.5±0.625	0.18	0.013	
2	±3	2.5±0.625	0.81	0.05	
3	±2	2.5±0.625	1.62	0.12	

7.- EDITION CONTROL

Edition	Date	Change description	Made by
1 st	25/08/10	First Edition	Marta Escolar
2 nd	02/11/10	Added the isolations characteristics and standards and marking, updated mounting dimensions	Marta Escolar

NOTES

All rights reserved. Passing on of this document, use and communication of contents not permitted without written authorisation.

	CUSTOMER	CUSTOMER CODE	PART DESCRIPTION HALL EFFECT CURRENT SENSOR CLOSED LOOP 6A		
	INTERNAL CODE HCT-06DSR5	DATE 02/11/10	EDITION 2	DOCUMENT NAME HCT-06DSR5_2.doc	PAGE 5/16

HCT-15DSR5 SERIES HALL EFFECT CURRENT SENSOR CLOSED LOOP

NOTES



All rights reserved. Passing on of this document, use and communication of contents not permitted without written authorisation.

	CUSTOMER	CUSTOMER CODE	PART DESCRIPTION HALL EFFECT CURRENT SENSOR CLOSED LOOP 6A		
	INTERNAL CODE HCT-06DSR5	DATE 02/11/10	EDITION 2	DOCUMENT NAME HCT-06DSR5_2.doc	PAGE 6/16

1.- DIMENSIONS AND PINS CONFIGURATION

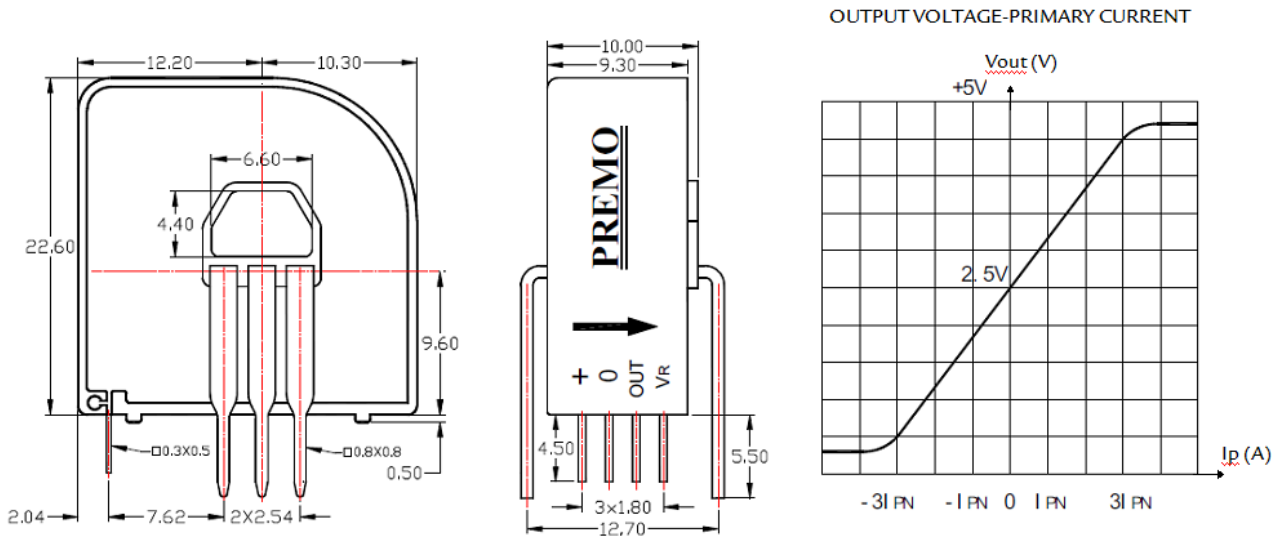

All dimensions are in mm.

General Tolerance ± 0.5 mm.

All dimensions and mechanical fixations are subjected to change depending on the customer necessities and PREMO Transducer Development.

The reference pin is only Output.

Marking

Component is marked as follows:

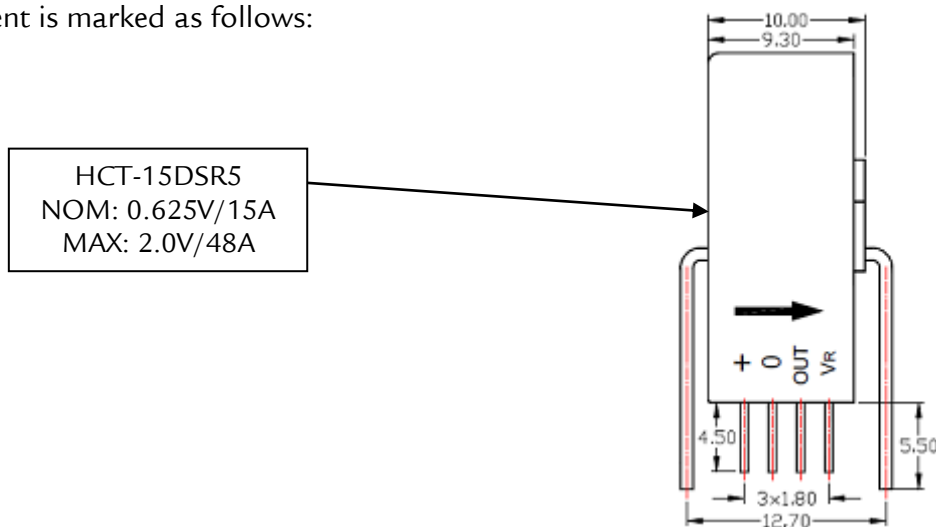

NOTES

All rights reserved. Passing on of this document, use and communication of contents not permitted without written authorisation.

	CUSTOMER	CUSTOMER CODE	PART DESCRIPTION HALL EFFECT CURRENT SENSOR CLOSED LOOP 6A		
	INTERNAL CODE HCT-06DSR5	DATE 02/11/10	EDITION 2	DOCUMENT NAME HCT-06DSR5_2.doc	PAGE 7/16

2.- ELECTRICAL PARAMETERS

Primary Nominal Current	15 A DC	I_{pn}
Measuring Range	48 A	I_p
Reference voltage	2.5±0.5% V	
Turns	1200±1	N
Supply Voltage	+5±5% V	V_{cc}
Rated output (V)	0.625±0.5%	
Sample resistance inside	100±0.1% Ω	R_{IN}

3.- ACCURACY

Linear Error	< 0.1 % Full Scale	e_{LLR}
Total precision	±0.7	
Offset Current Drift	± 0.5 % mV/°C	K_{Ios}
Time Response (di/dt>50 A/μS)	< 500ns	T_R
Frequency Bandwidth	DC to 200kHz (-1dB)	F_c

4.- GENERAL DATA

Operating Temperature	-40 to +85 °C	T_A
Storage Temperature	-40 to +125 °C	T_s

5.- ISOLATION CHARACTERISTICS

Galvanic isolation (50 Hz, 1min)	2.5 KV	V_i
Impulse withstand voltage 1.2/50μs	>8 KV MIN	V_w
Creepage distance	15.35 mm	d_{Cp}
Clearance distance	6.2 mm	d_{Cl}

STANDARDS

	EN 50178	UL 508C
Rating isolation voltage	600V	600V
Pollution degree	2	2
CTI	III	III

Notes:

-To be certificated

NOTES

All rights reserved. Passing on of this document, use and communication of contents not permitted without written authorisation.



	CUSTOMER	CUSTOMER CODE	PART DESCRIPTION HALL EFFECT CURRENT SENSOR CLOSED LOOP 6A		
	INTERNAL CODE HCT-06DSR5	DATE 02/11/10	EDITION 2	DOCUMENT NAME HCT-06DSR5_2.doc	PAGE 8/16

6.- MOUNTING DIMENSIONS (FOR REFERENCE ONLY)

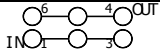
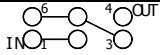
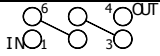
Turns	Primary rated current IPN[A]	Rated putout voltage VOUT[V]	Primary resistance [mΩ]	Primary Inductance [uH]	Connect point
1	±15	2.5±0.625	0.18	0.013	
2	±7.5	2.5±0.625	0.81	0.05	
3	±5	2.5±0.625	1.62	0.12	

7.- EDITION CONTROL

Edition	Date	Change description	Made by
1 st	25/08/10	First Edition	Marta Escolar
2 nd	02/11/10	Added the isolations characteristics and standards and marking, updated mounting dimensions	Marta Escolar

NOTES

All rights reserved. Passing on of this document, use and communication of contents not permitted without written authorisati on.

	CUSTOMER	CUSTOMER CODE	PART DESCRIPTION HALL EFFECT CURRENT SENSOR CLOSED LOOP 6A		
	INTERNAL CODE HCT-06DSR5	DATE 02/11/10	EDITION 2	DOCUMENT NAME HCT-06DSR5_2.doc	PAGE 9/16

HCT-25DSR5 SERIES HALL EFFECT CURRENT SENSOR CLOSED LOOP

NOTES



	CUSTOMER	CUSTOMER CODE	PART DESCRIPTION HALL EFFECT CURRENT SENSOR CLOSED LOOP 6A		
	INTERNAL CODE HCT-06DSR5	DATE 02/11/10	EDITION 2	DOCUMENT NAME HCT-06DSR5_2.doc	PAGE 10/16

1.- DIMENSIONS AND PINS CONFIGURATION

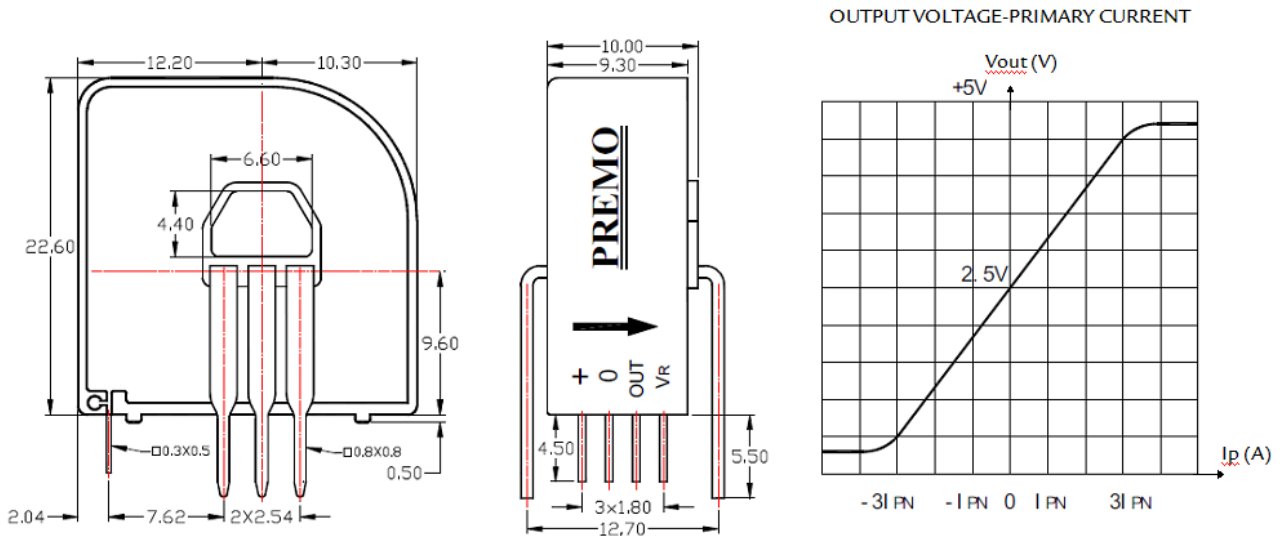

All dimensions are in mm.

General Tolerance ± 0.5 mm.

All dimensions and mechanical fixations are subjected to change depending on the customer necessities and PREMO Transducer Development.

The reference pin is only Output.

Marking

Component is marked as follows:

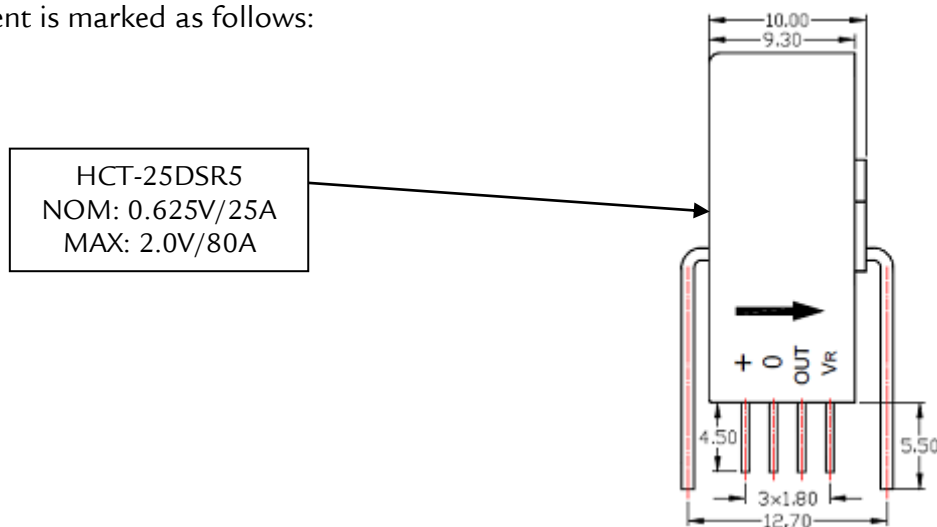

NOTES

All rights reserved. Passing on of this document, use and communication of contents not permitted without written authorisation.

	CUSTOMER	CUSTOMER CODE	PART DESCRIPTION HALL EFFECT CURRENT SENSOR CLOSED LOOP 6A		
	INTERNAL CODE HCT-06DSR5	DATE 02/11/10	EDITION 2	DOCUMENT NAME HCT-06DSR5_2.doc	PAGE 11/16

2.- ELECTRICAL PARAMETERS

Primary Nominal Current	25 A DC	I_{pn}
Measuring Range	80 A	I_p
Reference voltage	2.5±0.5% V	
Turns	2000±1	N
Supply Voltage	+5±5% V	V_{cc}
Rated output (V)	0.625±0.5%	
Sample resistance inside	50±0.1% Ω	R_{IN}

3.- ACCURACY

Linear Error	< 0.1 % Full Scale	e_{LLR}
Total precision	±0.7	
Offset Current Drift	± 0.5 % mV/°C	K_{Ios}
Time Response (di/dt>50 A/μS)	< 500ns	T_R
Frequency Bandwidth	DC to 200kHz (-1dB)	F_c

4.- GENERAL DATA

Operating Temperature	-40 to +85 °C	T_A
Storage Temperature	-40 to +125 °C	T_s

5.- ISOLATION CHARACTERISTICS

Galvanic isolation (50 Hz, 1min)	2.5 KV	V_I
Impulse withstand voltage 1.2/50μs	>8 KV MIN	V_w
Creepage distance	15.35 mm	d_{Cp}
Clearance distance	6.2 mm	d_{CI}

STANDARDS

	EN 50178	UL 508C
Rating isolation voltage	600V	600V
Pollution degree	2	2
CTI	III	III

Notes:

-To be certificated

NOTES

All rights reserved. Passing on of this document, use and communication of contents not permitted without written authorisation.



	CUSTOMER	CUSTOMER CODE	PART DESCRIPTION HALL EFFECT CURRENT SENSOR CLOSED LOOP 6A		
	INTERNAL CODE HCT-06DSR5	DATE 02/11/10	EDITION 2	DOCUMENT NAME HCT-06DSR5_2.doc	PAGE 12/16

6.- MOUNTING DIMENSIONS (FOR REFERENCE ONLY)

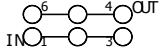
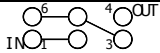
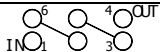
Turns	Primary rated current IPN[A]	Rated putout voltage VOUT[V]	Primary resistance [mΩ]	Primary Inductance [uH]	Connect point
1	±25	2.5±0.625	0.18	0.013	
2	±12.5	2.5±0.625	0.81	0.05	
3	±8.3	2.5±0.625	1.62	0.12	

7.- EDITION CONTROL

Edition	Date	Change description	Made by
1 st	25/08/10	First Edition	Marta Escolar
2 nd	02/11/10	Added the isolations characteristics and standards and marking, updated mounting dimensions	Marta Escolar

NOTES

All rights reserved. Passing on of this document, use and communication of contents not permitted without written authorisation.

	CUSTOMER	CUSTOMER CODE	PART DESCRIPTION HALL EFFECT CURRENT SENSOR CLOSED LOOP 6A		
	INTERNAL CODE HCT-06DSR5	DATE 02/11/10	EDITION 2	DOCUMENT NAME HCT-06DSR5_2.doc	PAGE 13/16

HCT-50DSR5 SERIES HALL EFFECT CURRENT SENSOR CLOSED LOOP

NOTES



All rights reserved. Passing on of this document, use and communication of contents not permitted without written authorisation.

	CUSTOMER	CUSTOMER CODE	PART DESCRIPTION HALL EFFECT CURRENT SENSOR CLOSED LOOP 6A		
	INTERNAL CODE HCT-06DSR5	DATE 02/11/10	EDITION 2	DOCUMENT NAME HCT-06DSR5_2.doc	PAGE 14/16

1.- DIMENSIONS AND PINS CONFIGURATION

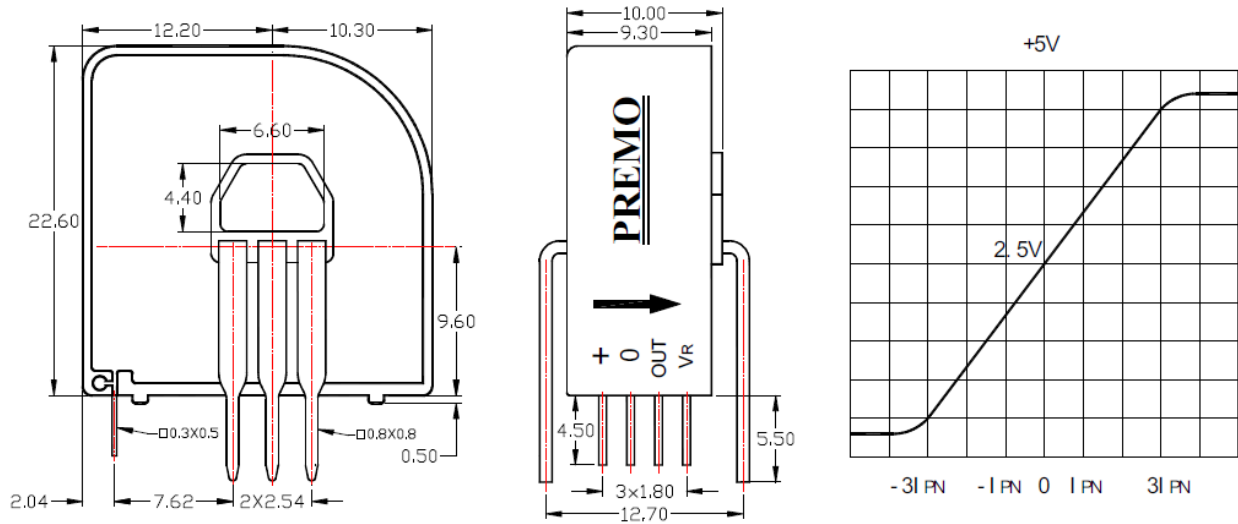

All dimensions are in mm.

General Tolerance ± 0.5 mm.

All dimensions and mechanical fixations are subjected to change depending on the customer necessities and PREMO Transducer Development.

NOTES



	CUSTOMER	CUSTOMER CODE	PART DESCRIPTION HALL EFFECT CURRENT SENSOR CLOSED LOOP 6A		
	INTERNAL CODE HCT-06DSR5	DATE 02/11/10	EDITION 2	DOCUMENT NAME HCT-06DSR5_2.doc	PAGE 15/16

2.- ELECTRICAL PARAMETERS

Primary Nominal Current	50 A DC	I_{pn}
Measuring Range	150 A	I_p
Galvanic isolation (50 Hz, 1min)	2.5 KV	
Turns	2000±1	
Supply Voltage	+5±5% V	V_{CC}
Rated output (V)	0.625±0.5%	
Sample resistor inside	25±0.1% Ω	
Reference voltage	2.5±0.5% V	

3.- ACCURACY

Linear Error	< 0.1 % Full Scale	e_{LLR}
Total precision	±0.7	
Offset Current Drift	± 0.5 % mV/°C	K_{Ios}
Time Response ($di/dt > 50 \text{ A}/\mu\text{S}$)	< 500ns	T_R
Frequency Bandwidth	DC to 200kHz (-1dB)	F_c

- * Electrical Parameters and frequency response to be checked with samples.

4.- GENERAL DATA

Operating Temperature	-40 to +85 °C	T_A
Storage Temperature	-40 to +125 °C	T_s

5.- MOUNTING DIMENSIONS (FOR REFERENCE ONLY)

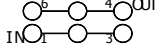
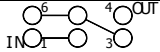
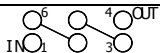
Turns	Primary rated current $I_{PN}[A]$	Rated putout voltage $V_{OUT}[V]$	Primary resistance [mΩ]	Primary Inductance [uH]	Connect point
1	±6(±15,±25,±50)	2.5±0.625	0.18	0.013	
2	±3(±7.5,±12.5,±25)	2.5±0.625	0.81	0.05	
3	±2(±5,±8.3,±16.6)	2.5±0.625	1.62	0.12	

NOTES

All rights reserved. Passing on of this document, use and communication of contents not permitted without written authorisation.



	CUSTOMER	CUSTOMER CODE	PART DESCRIPTION HALL EFFECT CURRENT SENSOR CLOSED LOOP 6A		
	INTERNAL CODE HCT-06DSR5	DATE 02/11/10	EDITION 2	DOCUMENT NAME HCT-06DSR5_2.doc	PAGE 16/16

6.- EDITION CONTROL

Edition	Date	Change description	Made by
1st	25/08/10	First Edition	Marta Escolar

NOTES



All rights reserved. Passing on of this document, use and communication of contents not permitted without written authorisation.